

## 25W CONSTANT CURRENT DIMMABLE DALI2 SERIES

Constant Current DALI2-series is constant current LED driver with 150 to 700 mA output current and the output current is selectable by DIP switch, it is easy to integrated in LED panel, downlight product. It is supported with short circuit and overload protection.

### → APPLICATION

- LED Panel
- LED Spot light
- LED Down light
- LED Strip light



### → FEATURES

- Flicker free & Dip Switch.
- Class II, SELV, independent.
- Protections: SCP/OLP/OVP/OTP.
- Power Factor  $>0.95$
- Efficiency  $\geq 85\%$ .
- Support DALI II, Push Dimming.
- Five years warranty.



**→ Technical data**

Input	Ac input voltage	220-264VAC
	DC input voltage	176-280V
	Frequency(Hz)	0/50/60 Hz
	Power Factor	> 0.95@220-240VAC, full load
	Input Current max	0.2A MAX. @Full Load,176VAC
	Start-up time	< 1S
	Unload Power Consumption	≤0.5W
	Inrush Current	30A Max.
Output	Constant Current	150/.../700mA
	No load voltage Max	Max 60 VDC
	Output voltage range	9-52VDC
	Rated power	26.3W Max.
	Load Regulation	±5%@220-240VAC
	Hold-up Time	1s max.@Full Load
	Efficiency(Typ.)	≥85%
Dimming	Dimmable	YES
	Dimming mode	DALI II, Push
	Dimming current range	5mA(min) ~100%
Protection	Over Load Protection	103-120% Protection type: Latch off
	Over Voltage Protection	> 60VDC Protection type: Latch off
	Short circuit Protection	Protection type: Latch off
	Over Temperature protection	Protection type:Auto Resume
Environment	Operating Temperature	-20°C...+50°C
	tc	85°C
	Humidity	20%-90%RH
	Safety standards	EN 61347-1; EN61347-2-13; EN62384
	Withstand voltage	Input-Output : 3750V/5mA/1min
	EMI	EN55015; EN61000-3-2 Class C; EN61000-3-3
	EMS	EN 61547; EN 61000-4-2; EN 61000-4-5 — 1000V;
	Dimension(LXWXH)	160X42X30mm
Note	Ripple and noise are measured at 20MHZ of bandwidth by using a 300mm twisted pair-wire terminated	
	All parameters NOT specially mentioned are measured at 240VAC input, full load and 25C of ambient temperature.	

## → ADJUSTABLE OUTPUT CURRENT WITH DIP-SWITCH

Vo	Po	Io	1	2	3	4
9-52VDC	7.8 W	150mA	--	ON	--	--
9-52VDC	10.4 W	200mA	--	ON	--	ON
9-52VDC	13 W	250mA	--	ON	ON	--
9-52VDC	15.6 W	300mA	--	ON	ON	ON
9-52VDC	18.2 W	350mA	ON	--	--	--
9-52VDC	20.8 W	400mA	ON	--	--	ON
9-52VDC	23.4 W	450mA	ON	--	ON	--
9-52VDC	26 W	500mA	ON	--	ON	ON
9-47.5VDC	26.1 W	550mA	ON	ON	--	--
9-43.5VDC	26.1 W	600 mA	ON	ON	--	ON
9-40VDC	26 W	650 mA	ON	ON	ON	--
9-37.5VDC	26.3 W	700mA	ON	ON	ON	

## → WIRING DIAGRAM

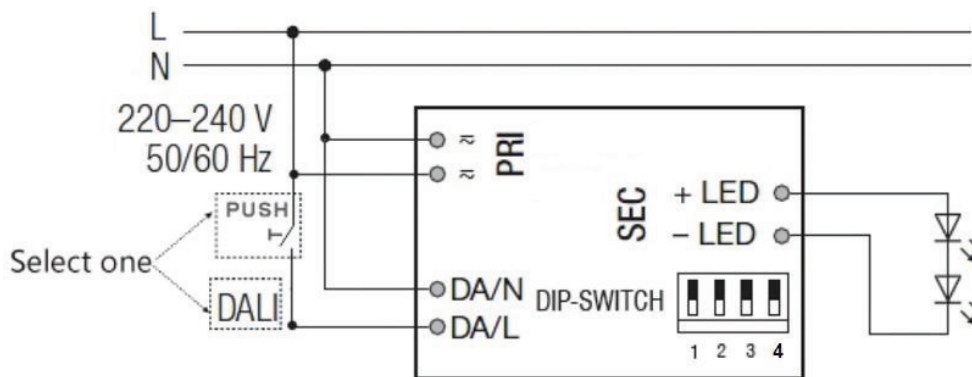

**➔ FUNCTION CURVE FOR QPEC-DAL2-25-700 EDS, IO=700MA**

**LIFETIME VS. AMBIENT TEMPERATURE CURVE    EFFICIENCY VS. LOAD**

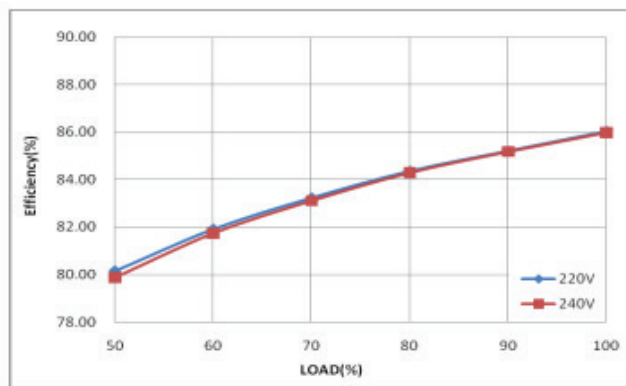
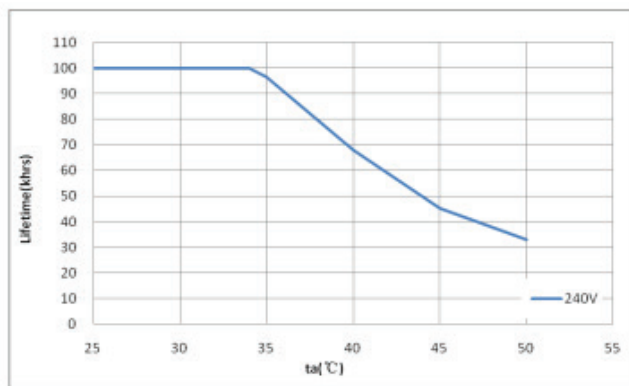

**POWER FACTOR CHARACTERISTICS**

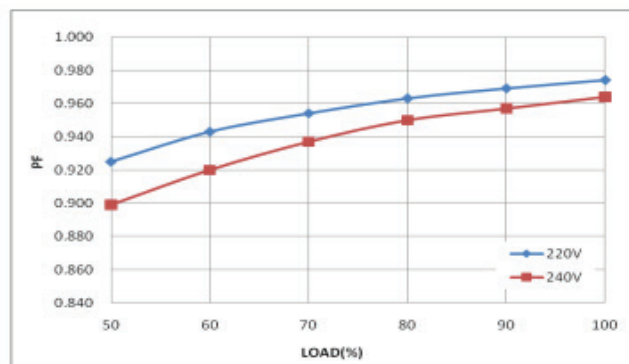

**THD VS. LOAD**

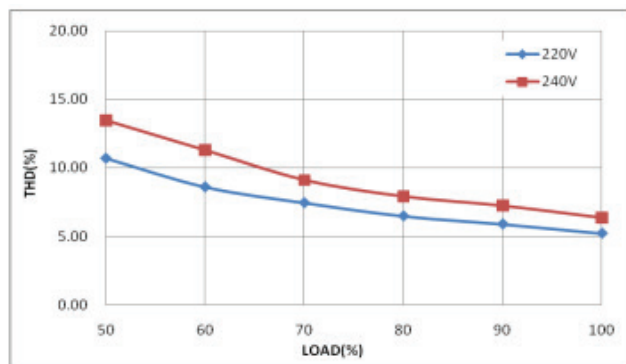

**LED DRIVER INDOOR  
CONSTANT CURRENT  
DIMMABLE - DALI2**

**QPEC-DAL2-25-700 EDS**

## → DIMENSIONS

