

45W CONSTANT VOLTAGE DIMMABLE DALI2 SERIES

constant Voltage LED driver that operates from 176-264Vac input with 24V output voltage. With it's compact dimensions from 187 x 45 x 30.5 mm it is easy to integrate in linear light and troffer light products. To ensure trouble-free operation, protection is provided against output short circuit and over Load.

→ APPLICATION

- LED Strip
- LED Linear light
- LED Troffer light



→ FEATURES

- Flicker free
- Class II, SELV, independent
- Protections: SCP/OLP/OVP
- Power Factor >0.95
- Efficiency ≥86%.
- Support DALI II , Push Dimming
- Five years warranty



➔ **Technical data**

Input	Rated input Voltage	220-240VAC
	Range of input voltage	176-264VAC
	DC voltage range	176-280V
	Frequency(Hz)	0/50/60 Hz
	Power Factor	> 0.95@Full Load,230VAC
	Input Current max	0.35A MAX. @Full Load,176VAC
	Start-up time	< 1S
	Unload Power Consumption	≤ 0.5W
	Inrush Current	40A Max.
Output	Constant Voltage	24VDC
	Output voltage Range	0-1.88.A
	Rated power	45W Max.
	Load Regulation	≤ 2%
	Hold-up Time	1s max.@Full Load
	Efficiency(Typ.)	≥ 86%
Dimming	Dimmable	YES
	Dimming mode	DALI II, Push
	Dimming current range	1%~100%
Protection	Over Load Protection	105-150% Protection type: Auto Resume
	Over Voltage Protection	> 25.2VDC Protection type: Auto Resume
	Short circuit Protection	Protection type : Latch off , Auto recovery after power off and restart
	Over Temperature protection	Protection type: Auto Resume
Environment	Operating Temperature	-20℃…+50℃
	tc	85℃
	Storage Temperature	-30℃…+65℃
Safety & EMC	Humidity	20%-90%RH
	Safety standards	EN 61347-1; EN61347-2-13; EN62384;
	Withstand voltage	Input-Output : 3750V/5mA/1min
	EMI	EN55015; EN61000-3-2 Class C; EN61000-3-3
	EMS	EN 61547; EN 61000-4-2; EN 61000-4-5 —1000V;
	Dimension	187X45X30.5(LXWXH)mm
Note	Ripple and noise are measured at 20MHZ of bandwidth by using a 300mm twisted pair-wire terminated	
	All parameters NOT specially mentioned are measured at 240VAC input, full load and 25C of ambient temperature.	

→ MODEL LIST

No.	Model number	Input			Output		
		Voltage (VAC)	Max.Current (A)	Frequency (Hz)	Constant voltage (V)	Normal working current (VDC)	Max Power (W)
1	QPEV-DAL2-45W-24 E	220-240	0.35	50/60	24	0-1.88	45

→ MAXIMUM LOADING OF AUTOMATIC CIRCUIT BREAKERS IN RELATION TO INRUSH CURRENT

Automatic circuit breaker type	C10	C13	C16	C20	B10	B13	B16	B20
Installation \emptyset	1.5mm ²	1.5mm ²	1.5mm ²	1.5mm ²	1.5mm ²	1.5mm ²	1.5mm ²	1.5mm
QPEV-DAL2-45W-24 E	16	20	24	28	13	16	19	22

These are max values calculated out of inrush current! Please consider not to exceed the maximum rated continuous current of the circuit breaker. Actual values may differ due to used circuit breaker types and installation environment.

→ WIRING

LED wire length Grunes internally verified the wire length from LED driver to LED module at full load is up to 18 meter Chose a proper wire thickness to reduce the voltage drop effect .

Wire cross section	mm ²	1.0mm ²	105mm ²
	AWG	17	15
Maximum cable length		10m	18m

The values are indicative. Each connection may increase the total voltage drop.

**LED DRIVER INDOOR
CONSTANT VOLTAGE
DIMMABLE - DALI2**

QPEV-DAL2-45W-24 E

→ WIRING DIAGRAM

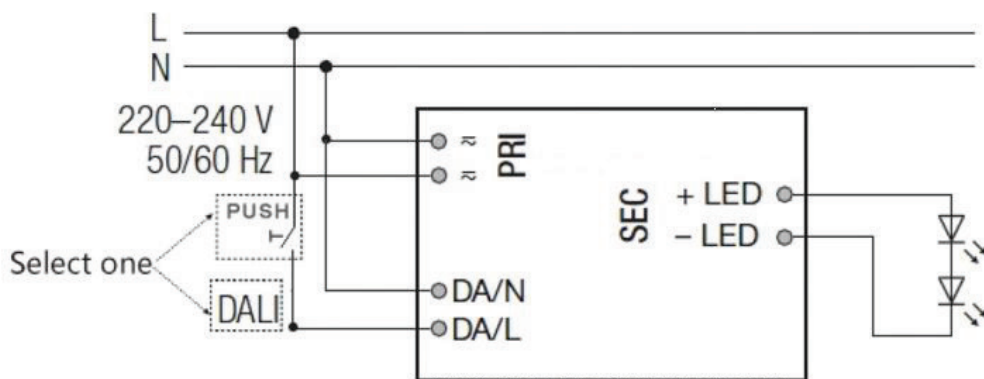

→ DIMENSIONS

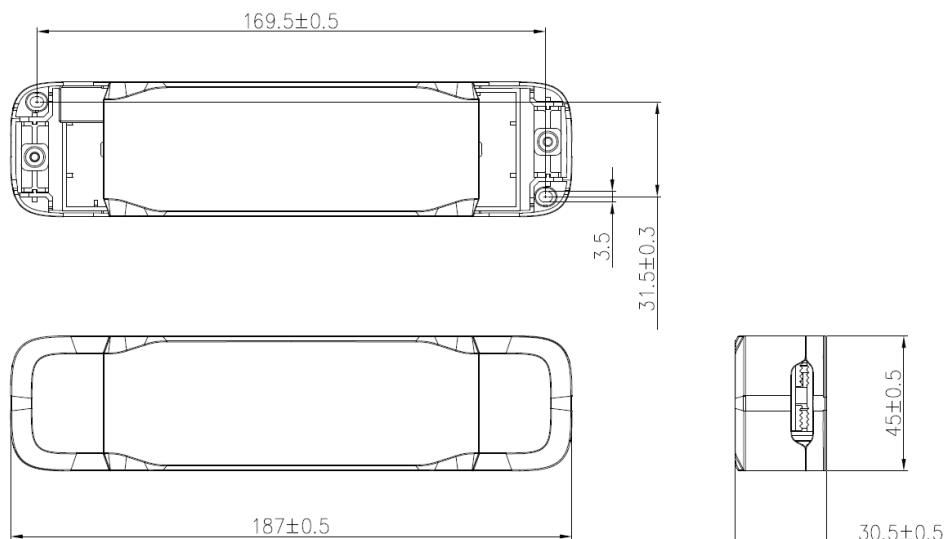

CURVE

LIFETIME VS. AMBIENT TEMPERATURE

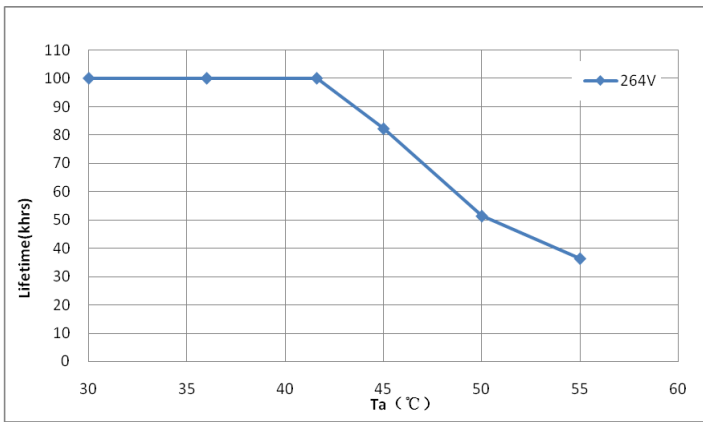

EFFICIENCY VS. LOAD

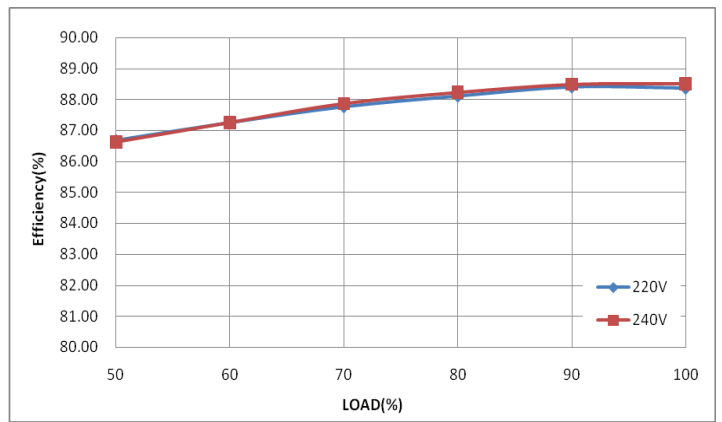

POWER FACTOR CHARACTERISTICS

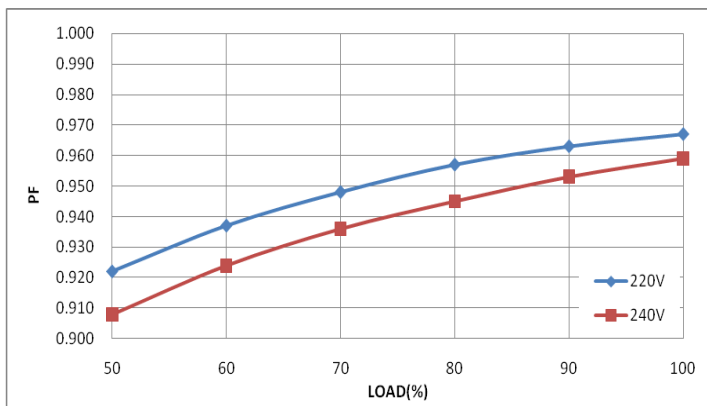

THD VS. LOAD

