

QPHVO-DALI-300-24V-IP20

QPHVO-DALI-300-24V-IP20

QPHVO-DALI-300-24V-IP20 is a 42w constant voltage LED driver that operates from 170-264Vac input with 24V output voltage. With dimensions from 287 x 49 x 29 mm it is easy to integrate in LED strips, linear light and troffer light products. To ensure trouble-free operation, protection is provided against output short circuit, over Load and overvoltage.

→ APPLICATION

- LED panel
- LED spot light
- LED down light
- Strip light



→ FEATURES

- 170-264VAC
- Protection shortcircuit /overload/overvoltage
- Working temperature with 60 c
- Cooling by free air convection
- 100% full load burn - in test
- Support DALI
- Three years warranty

CE RoHS BIS SELV IP20 

→ Technical data

	Model	QPHVO-DALI-300-12V-IP20	QPHVO-DALI-300-24V-IP20
Output	DC Voltage		
	Voltage Tolerance	± 0.5V	
	Rated Current	0 - 25A	0 - 12.5A
	Rated Power	300W	300W
	Ripple & Noise	250mVp-p	250mVp-p
Input	Voltage Range	170-264VAC	
	Frequency Range	50 - 60HZ	
	Power Factor	PF ≥ 0.5/220VAC (Full loading)	
	Full Load Efficiency(Typ.)	86%	86%
	AC Current (Max.)	1.92A	1.9A
	Leakage Current	< 0.5mA/260VAC	
	Inrush Current	≤ 60A	
Protection	Short Circuit	Protection type: Hiccup mode, recovers automatically after fault condition is removed.	
	Over Load	Hiccup mode, recovers automatically after fault condition is removed	
	VIBRATION	10-500Hz 2G10min	
	BURNT-IN TEST	Input voltage: 220V 50Hz rated output current 25°C Bum-in 2h	
Environment	Over Temperature	100°C ± 10°C shut down o/p voltage, re- poweron to recover	
	Working TEMP.	- 20 ~ + 50°C	
	Working Humidity	20~60%RH, non-condensing	
	Storage TEM., Humidity	- 20 ~ + 85%, 10~95%RH	
	START RISE HOLD TIME	1500ms, 20ms, 50ms/230VAC at full load	
Safety & EMC	Vibration	10 - 500Hz, 5G 12min./1 cycle, period for 60min.each along X,Y,Z axes.	
	Safety Standards	CE Mark	
	Withstand Voltage	I/P- O/P: 1.5KVAC I/P- GND: 1.5KVAC	
	EMC Immunity	EN55015:2013; EN61547:2009; EN61000-3-2:2014; EN61000-3-3:2013	
Others	Weight	0.50Kg	
	Dimension	287x49x29mm (LxWxH)	
	Packing	40pcs/CTN	
Notes	<ol style="list-style-type: none"> All parameters NOT specially mentioned are measured at 230VAC input , rated load and 25°C of ambient temperature. Tolerance: includes set up tolerance, line regulation and load regulation . The power supply is considered as a component that will be operated in combination with final Equipment. Since EMC performance will be affected by the complete installation, the final equipment manufactures must be- qualify EMC Directive on the complete installation again. 		

QPHVO-DALI-300-24V-IP20

→ MECHANICAL SPECIFICATION

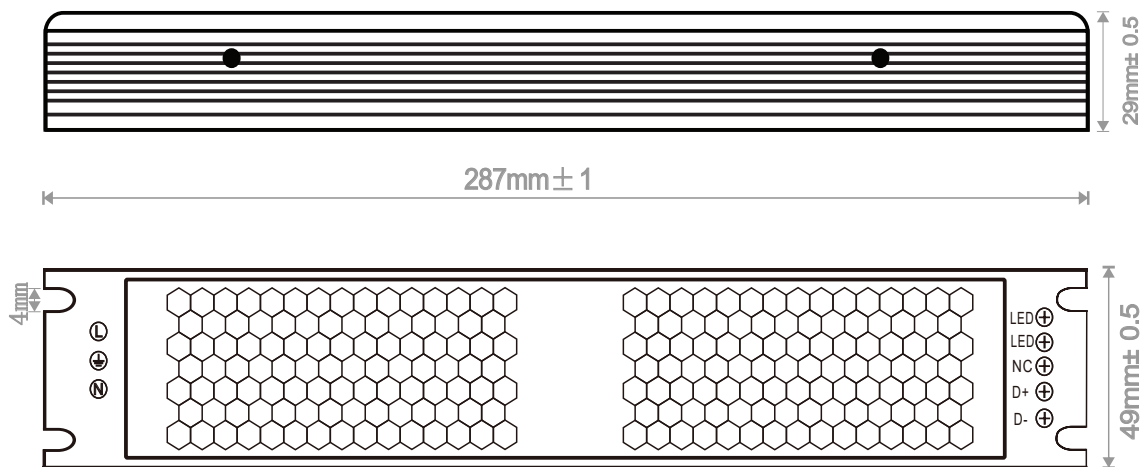

→ DERATING CURVE

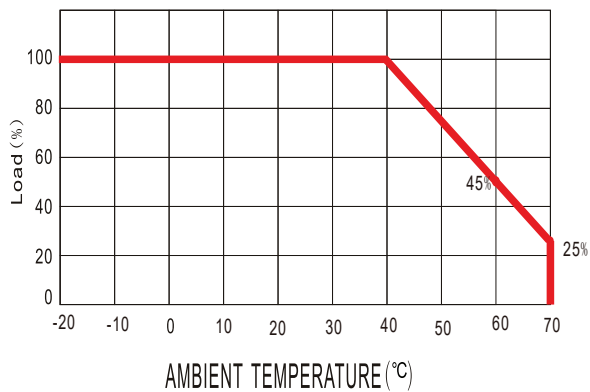

Package

DIMENSION	287x49x29 (mm) (L×W×H)
CARTON QUANTITY	40PCS/Carton
CARTON SIZE	370x300x29.5 (mm)
WEIGHT	500g /PCS

LED DRIVER INDOOR
CONSTANT Voltage
DIMMABLE - DALI

QPHVO-DALI-300-24V-IP20

→ SWITCHING TIME CURVE

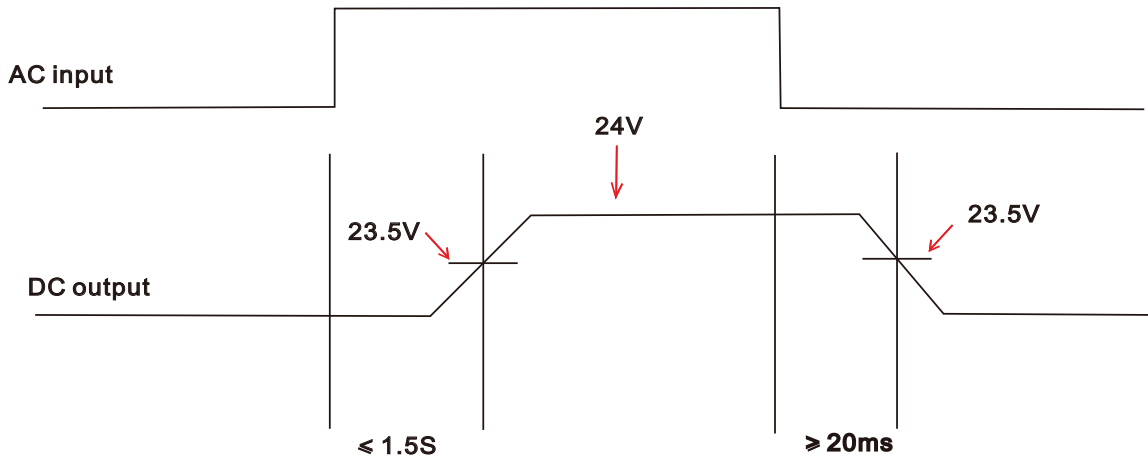

→ DIMMING OPERATION

